

# KMW<sup>®</sup>

## KÜHLMÖBELWERK

Qualität aus Deutschland

# Operating Manual

## Refrigerated display cabinet

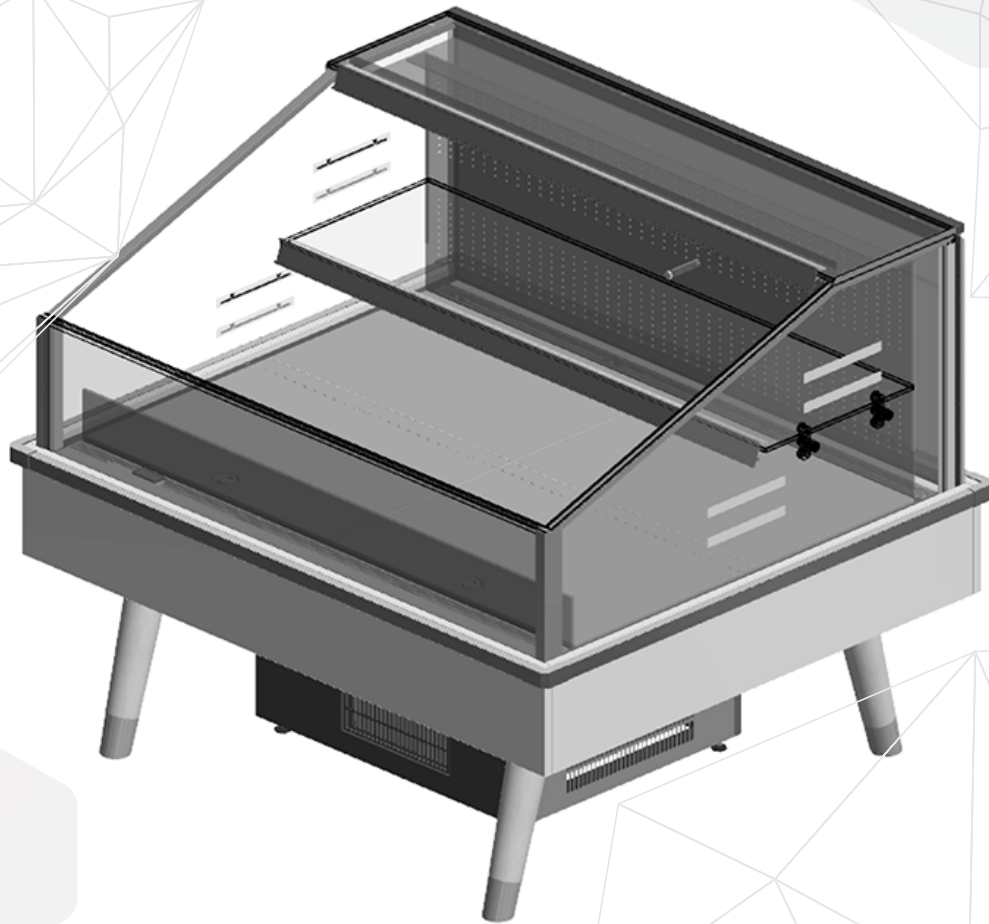

## Usedom

# Commercial refrigerated cabinet

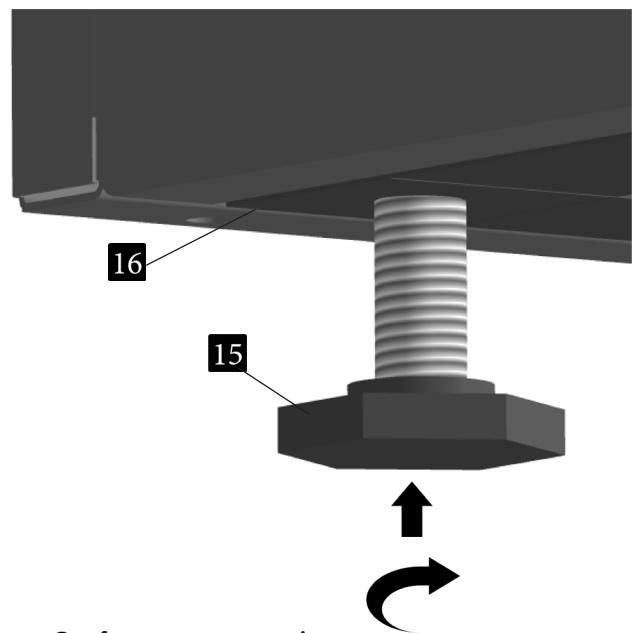
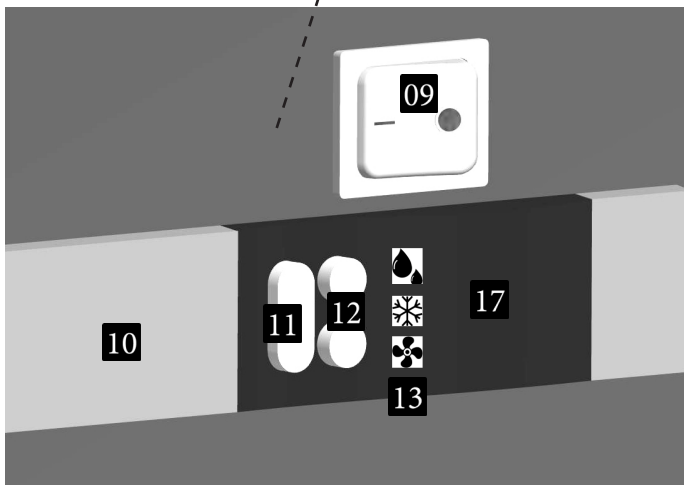
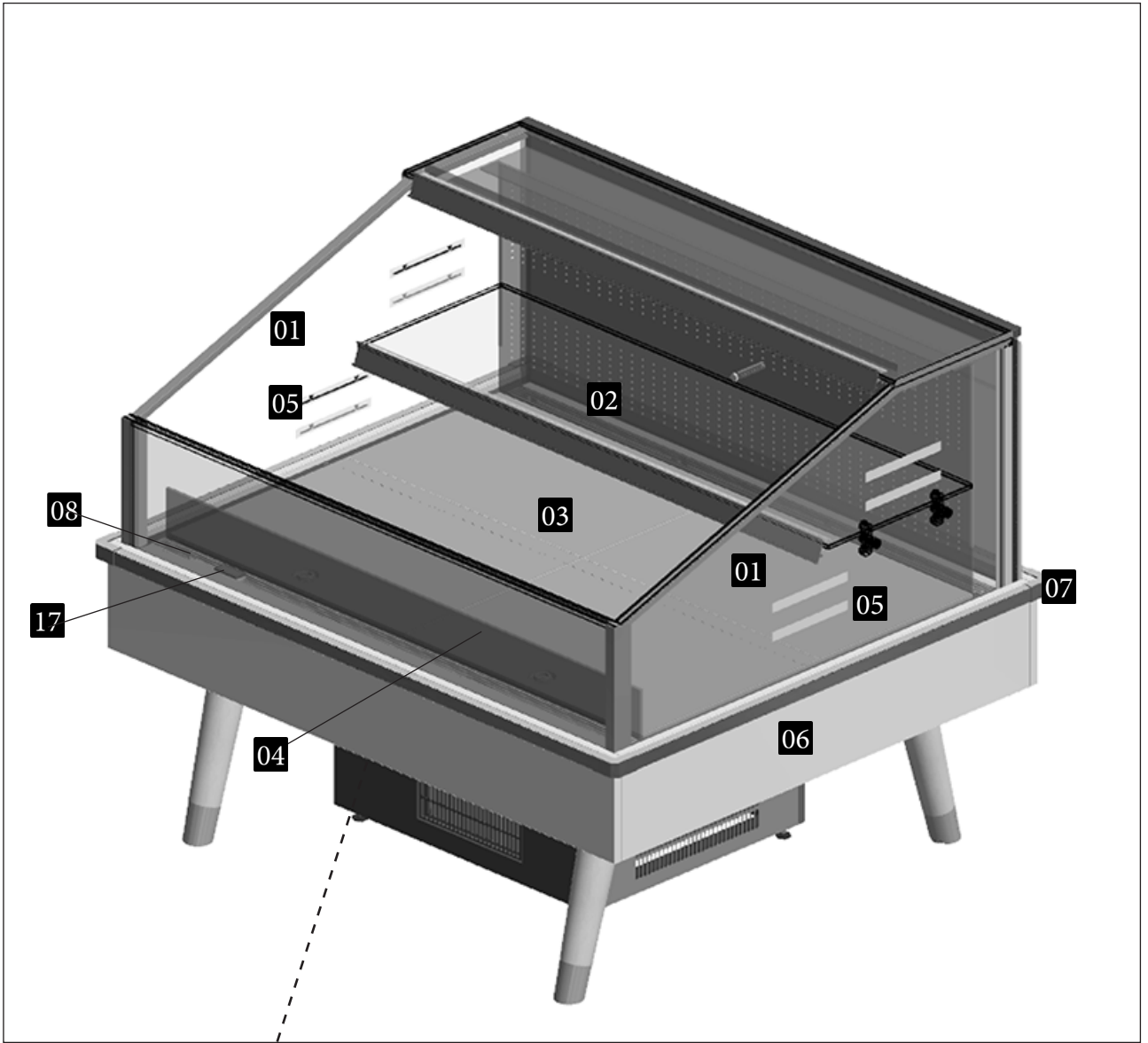

 defrost running

 cooling is running

 fans are running

- 01 glass panes outside
- 02 glass shelf
- 03 floor display
- 04 battle plate inside
- 05 load limit line
- 06 decorative panel
- 07 impact protection
- 08 air intake grille
- 09 light switch LED (optional)
- 10 thermostat controller
- 11 program keys
- 12 button forward-back
- 13 display icons 
- 14 temperature display
- 15 adjustable feet with thread M10
- 16 substructure
- 17 temperature display, weighted air inlet and air outlet temperature

# Contents

<b>General</b>	5
Read and keep the operating instructions	5
<b>Explanation of symbols</b>	5
<b>Intended use</b>	6
<b>Safety</b>	7
Danger of explosion	8
Risk of ignition and explosion	8
Electric shock hazard	8
Safety instructions for the authorized specialist	9
Risk of health consequences	10
Risk of injury	10
Malfunction caused by electromagnetic interference	10
<b>Lineup</b>	11
<b>Installation</b>	12
Electric shock warning	12
Electric circuit protection	12
Electric circuit breaker	12
Connect and disconnect the refrigeration island from the power supply	12
<b>Cleaning</b>	13
Do not clean with:	13
<b>Defrost</b>	13
Defrosting of devices without bus connection	13
Defrosting of devices with bus connection	13
<b>Maintenance</b>	14
Risk of injury	14
Risk of circuit	14
<b>Decommissioning, transport and storage</b>	15
<b>Product details and functionality</b>	15
Climate class	15
Cooling unit	15
Housing and cooling storage	15
Temperature controller / Refrigeration controller	16
<b>Troubleshooting and service</b>	17
Contact address	17
<b>Disposal</b>	18
Dispose of packaging	18
Dispose of cooling island	18
<b>Energy label climate class III (25°C;60%r.F.)</b>	18
<b>Technical specifications</b>	18
<b>Declaration of Conformity</b>	19
<b>Imprint</b>	20

## General

### Read and keep the operating instructions



These operating instructions belong to the Use-dom model series (herein-after referred to as "freshness cooler"). It contains important information on commissioning and handling.

Read the operating instructions, especially the safety instructions carefully, before using the freshness cooler. Failure to follow these operating instructions can result in serious injury or damage to the cooler.

The operating instruction is based on the standards and regulations valid in the European Union. Also observe country-specific guidelines and laws abroad.

Keep this operating instruction for further use. If you pass the cooler on to third parties, be sure to include these operating instructions.

## Explanation of symbols

The following symbols and signal words are used in this user manual, on the freshness cooler or on the packaging:



**Danger!**

This signal symbol/word indicates a hazard with a high level of risk which, if not avoided, will result in death or serious injury.



**Warning!**

This signal symbol/word indicates a hazard with a medium level of risk which, if not avoided, will result in death or serious injury.



**Caution!**

This signal symbol/word indicates a hazard with a low level of risk which, if not avoided, will result in minor or moderate injury.



**Notice!**

This signal word warns of possible damage to property.



This symbol gives you useful additional information on installation or operation.



Products marked with this symbol comply with all applicable Community regulations of the European economic area (see chapter „Declaration of Conformity“).



Beware of flammable substances



Beware of electrical voltage



Beware of hot surfaces



Caution danger of explosion



Entering the surface prohibited



Read the user manual

## Intended use



### Notice!

The freshness cooler is a commercial refrigeration unit. It is designed as sales furniture for packaged food in temperature class M1 in the self-service area. The freshness cooler is not suitable for use on board ships or aircrafts. It must be ensured that the set and reached temperature inside the freshness cooler corresponds to the respective storage temperature of the food in question all the time.

## Safety

The freshness cooler is all around glazed and is delivered fully assembled (ready to plug in). Apart from the correct alignment at the installation site, final assembly by the user is not required.



The person responsible on site (e.g. the store manager in the case of installation in a supermarket) must ensure that the operators of the freshness cooler at the installation site are instructed in the correct use of the present operating manual and are familiar with it.

The freshness cooler meets all the requirements of EU Directive 2011/65EU (RoHS2) on the avoidance of hazardous substances in electrical and electronic equipment and EU Directive 1907/2006 (REACH) on the registration, evaluation and approval of chemicals. The refrigeration system installed in the cooler works with the refrigerant R290 (propane) and the insulating foam polystyrene.

- The global warming potential (GWP) corresponds to the value 3 and the ozone depletion potential (ODP) to the value 0.



Technical data and filling quantities can be found on the type plate of the cooler and on the product data sheet, which you can obtain from KMW customer service.

Only use the freshness cooler as described in this user manual. Any other use is considered improper and can lead to property damage or even personal injury.

The freshness cooler is not a child's toy. The manufacturer assumes no liability for any injury, loss or damage resulting from improper or improper use. Possible examples of improper or incorrect use are:

- Use of the freshness cooler for purposes other than those for which it is intended
- Non-observance of the safety instructions and warnings, as well as the assembly, operation, maintenance and cleaning instructions contained in this operating manual
- Non-observance of any accident prevention regulations specific to the use of the cooler and/or generally applicable
- Use of accessories and spare parts that are not intended for the freshness cooler
- Changes to the freshness cooler
- Repair of the freshness cooler by someone other than the manufacturer or a specialist
- Operation or maintenance of the freshness cooler by persons who are not familiar with the handling of the freshness cooler and/or do not understand the dangers involved.

## Danger of explosion



There is a risk of explosion if the freshness cooler is used or handled improperly.

Do not store any explosive substances such as aerosol containers with flammable propellants in the cooler.

## Risk of ignition and explosion



The freshness cooler is operated with the refrigerant R290 (propane). According to the DIN EN 378-1 standard, this is assigned to refrigerant group A3 (flammable and explosive).

If the freshness cooler is handled improperly, there is a risk that an inflammable gas-air mixture will form and be ignited unintentionally.



Never close the ventilation openings.



Do not use any mechanical devices or other means than those recommended by the manufacturer to speed up the defrosting process.



Never damage the refrigerant circuit.



Do not operate any electrical equipment inside the refrigerator that is not of the type recommended by the manufacturer.

## Electric shock hazard



Faulty electrical installation or excessive mains voltage can lead to electric shock.

## Safety instructions for the authorized specialist

- Only connect the freshness cooler if the mains voltage and mains frequency of the socket correspond to the information on the rating plate.
- Only connect the cooler to an easily accessible socket so that you can quickly disconnect the cooler from the power supply in the event of a malfunction.
- Do not operate the freshness cooler if it shows visible damage or if the mains connection cable or mains plug is defective.
- If the mains connection cable of the freshness cooler is damaged, it must be replaced by the manufacturer or its customer service or a similarly qualified person in order to avoid hazards.
- Do not open the housing; leave repairs to authorized specialists. To do this, contact KMW customer service. Liability and guarantee claims are excluded in the event of repairs carried out independently, improper connection or incorrect operation.
- Never touch the mains plug of the cooler with wet hands.



- Never pull the mains plug of the freshness cooler out of the socket by the mains connection cable, but always use the mains plug.
- Keep the freshness cooler, the mains plug and the mains connection cable away from open flames and hot surfaces.
- Lay the mains connection cable in such a way that it does not become a tripping hazard.
- Do not kink the power cord and do not lay it over sharp edges.
- Only use the freshness cooler in dry indoor areas.
- Disconnect the freshness cooler from the power supply by unplugging the power cord from the outlet when cleaning the freshness cooler or when servicing the freshness cooler. During the entire cleaning and maintenance process, it must be ensured that the fresh food cooler is disconnected from the power supply. The operator must be able to check whether the mains plug is outside the socket during the entire cleaning or maintenance process.
- If you discover or suspect malfunctions or damage to the temperature controller that endanger safe operation, take the cooler out of operation immediately.
- Only allow repair and maintenance work or adjustments to the temperature controller to be carried out by authorized specialists. To do this, contact KMW customer service.

### **Safety instructions for the authorized specialist**

Only parts that correspond to the original device data may be used for repairs.

- This cooler contains electrical and mechanical parts that are essential to protect against sources of danger.
- Do not operate the freshness cooler with an external timer or a separate remote control system.
- Incorrect installation of the temperature controller installed in the freshness cooler can lead to an electric shock. The temperature controller is installed and adjusted at the factory.
- Do not manipulate or change the temperature controller and never open the housing.
- Make sure that the entire system is switched off when the temperature controller is mounted, wired or dismantled.
- Please note that mains voltage and/or external voltage may be present when the control voltage is switched off.
- Use suitable professional tools for all work.
- Check all wiring after the Temperature Controller installation is complete.
- Observe the information on the maximum load for all connections (see chapter „Technical Data“ for the temperature controller).
- Keep any liquids (e.g. condensed water, cleaning agents, etc.) away from the temperature controller.

## Risk of health consequences



If the freshness cooler is handled improperly or if there is a lack of control, there is a risk that the food stored in the freshness cooler will be damaged and possibly spoil.

If the freshness cooler is disconnected from the power supply unexpectedly, e.g. in the event of a power failure, the person responsible on site must ensure that the stored food is checked. Compliance with the prescribed storage temperature must be ensured.

Clean up spilled liquids in the goods area immediately.

## Risk of injury



There is a risk of injury if used improperly. Check at regular intervals whether there are foreign objects in the goods area and remove them.

If defrost water leaks out of the freshness cooler, wipe it up immediately; otherwise there is a significant risk of people slipping and injuring themselves.

When cleaning the freshness cooler, always use suitable protective gloves to protect against injuries from sharp device edges.

The market operator himself commit to repair minor damage to the freshness cooler that does not impair any technical functions (e.g. dents in the housing caused by shopping trolleys).

If there is damage to the refrigeration system or the electrics, the KMW customer service must be informed immediately. Otherwise there is a considerable risk of injury.



In case of improper handling or use, there is a risk of damaging the cooler and causing property damage.

Always make sure that the freshness cooler is level on all sides and stands on all four feet securely when you put it into operation.

Observe the installation instructions in these operating instructions.

Never expose the freshness cooler to direct sunlight and keep the freshness cooler away from heat sources.

Always note that the freshness cooler must not heat up above the following temperatures: +50°C (during operation) and +70°C (during transport and storage).

## Malfunctions caused by electromagnetic interference

Improper installation of the temperature controller or improper connection to the Wurm system can result in malfunctions. Only use shielded data lines for installation and connection.

When installing the data lines, keep a large distance to load lines.

## Lineup

Unpack the freshness cooler and remove all packaging material after delivery. Check whether the delivery is complete and also pay attention to whether there are any loose parts in or on the removed packaging material.



Check whether the freshness cooler or individual parts show signs of damage. If this is the case, do not use the freshness cooler. Contact KMW customer service immediately.

- The installation location of the cooler should correspond to the environment defined by climate class 3 (max. 25°/60% RH) and be well ventilated.
- The ventilation slots in the base must be free and should not be covered or blocked.
- When installing a freshness cooler in a single or row installation, a minimum distance of 50mm to all four boundary surfaces such as walls, other devices, shelves, etc. must be maintained.
- The installation location should not be exposed to excessive drafts or large heat sources. This can impair the performance of the freshness cooler.
- In the case of block or row configurations, these must be ordered in advance to match.
- Other installations and superstructures should be avoided at the installation site in order to prevent heat build-up.
- Before using it for the first time, clean all parts of the cooler as described in the „Cleaning“ and „Maintenance“ chapters.



### Risk of damage!

- Do not drive the freshness cooler over steps.
- Never drill into the freshness cooler and do not modify it in any other way.
- Place the freshness cooler at the selected location.
- Align the cooler horizontally using the four feet.

## Installation

### Electric shock warning



Faulty electrical installation or excessive mains voltage can lead to electric shock. When connecting the freshness cooler, take into account the valid regulations of the local electrical supply company for your region, as well as all generally applicable national standards and safety regulations and comply with them. Make sure that the circuit is adequately protected. Only connect the freshness cooler if the mains voltage and mains frequency of the socket correspond to the information on the rating plate.

Only allow work on the electrical system to be carried out by KMW-authorized specialists. Also only have a damaged power cord replaced by KMW-authorized specialists.

Do not connect the freshness cooler to multiple socket strips and do not use extension cords.

Observe the following criteria for the power supply and connection components:

All supply cables must be laid by a specialist electrician in accordance with the VDE 0100-410 standard. Only connect the cooler to earthed sockets with earthing contact. Never connect more than two devices to a circuit. The cable length is 300 cm.

Make sure that the fresh food cooler does not switch off automatically when the market light is switched off.

Make sure that no other consumers are connected to the sockets for connecting the fresh food cooler.

KMW recommends using a cable duct on the floor with sockets built into it or mounted on it to connect the cooler.

## Electric circuit protection

Before connecting the freshness cooler to an electrical circuit, you must ensure that the corresponding electrical circuit is correctly secured. Miniature circuit breakers (LS switches) for protection against overcurrent and residual current circuit breakers (FI switches) for protection against residual currents are required for the proper protection of the circuit.

In addition to separate solutions for LS and FI switches, it is also possible to install a combined FI/LS switch.

### Slow circuit breakers

To ensure optimum operational safety, KMW recommends securing each device with its own slow-blow circuit breaker. Slow-blow miniature circuit breakers (LS switches) represent the minimum requirement for protecting the circuit. The LS switches used for this must meet the following criteria:

- LS switch with 16A
- KMW recommends tripping characteristic „C“; however, „B“ can also be used.

### Connect and disconnect the cooler from the power supply

The freshness cooler is equipped with a dark and a light connection cable. Plug the dark mains plug into a properly installed safety socket to connect the freshness cooler to the mains. The freshness cooler starts to cool automatically with a delay of 2 minutes.



During commissioning, the controller time must be adjusted to the current time of day

Plug the light-colored mains plug into the controllable socket of the store's central light control to connect the LEDs of the freshness cooler.

## Cleaning

- Pull the mains plug out of the socket before cleaning.
- Wipe the device surfaces with a slightly damp cloth. For heavier soiling, use neutral soap and water.
- Clean all glass panes and glass displays with a soft cotton cloth or a highly absorbent sponge cloth, a glass squeegee and a dry cotton cloth to wipe dry. Here, too, only use water and a neutral cleaning agent (pH5-7) for heavy soiling.

After cleaning with detergents, wipe all cleaned surfaces with clear water and remove all residues of the detergent from all surfaces of the freshness cooler. Remaining cleaning agent residues can damage the material over time and impair the function of the device parts. Dry all cleaned surfaces.

### **Never clean with:**

- Rubbing, scouring or chemically aggressive cleaning agents with a strongly acidic pH value of less than 4 or a strongly alkaline pH value of more than 8
- microfiber cloths
- Hard or sharp metal objects (e.g. glass plane, glass blade, steel wool)
- Steam or high-pressure cleaner.

## Defrost

The freshness cooler is equipped with an automatic defrosting system that works on the principle of so-called „hot gas defrosting“. It is therefore usually not necessary to defrost the freshness cooler manually. The start time of the automatic defrosting process is preset at the factory. In exceptional cases, it may be necessary to defrost the cooler manually, e.g. due to a fault, improper installation, overloading, after cleaning or due to other sources of interference. The way you do this depends on whether your freshness cooler is connected to a wurm system or not.

### **Defrosting devices without a bus connection**

Disconnect the freshness cooler from the power supply by pulling the mains plug out of the socket.

- Wait about a minute.
- Reconnect the freshness cooler to the power supply by inserting the mains plug into a properly installed grounded socket.
- After reconnecting, the freshness cooler automatically starts the defrosting process. After the defrosting process is complete, the freshness cooler automatically switches back to cooling mode.
- After the defrosting process is complete, check the temperature in the refrigerator compartment of the fresh food cooler.
- In the case of very heavy icing, it may be necessary to repeat this process up to three times.

### **Defrosting devices with bus connection**

In the case of freshness coolers that are connected to a Wurm system via a bus connection, the manual defrosting process is also initiated via the store software or according to separate instructions directly on the thermostat controller. Please note the information and operating instructions for the Wurm system used.

## Maintenance

The freshness cooler is largely maintenance-free. For reasons of hygiene, the manufacturer recommends completely defrosting and cleaning the cooler once or twice a year.

The condenser and the condensate drain should also be cleaned once or twice a year by suitable, expert personnel or a specialist refrigeration company.



Attention! The surface of the condenser could be hot. Risk of burns!

### Risk of ignition and explosion



A flammable gas-air mixture can form due to any existing leaks in a refrigeration system operated with the refrigerant R290. Sparks emitted by an electrical device (e.g. a vacuum cleaner) can ignite the gas-air mixture that may be present. For devices that are operated with the refrigerant R290, remove condensation water only with a dry cloth or sponge. Do not use electric wet vacuum cleaners or similar.

Never hit or scrape off any existing layer of ice or frost with pointed objects or tools. This could damage the evaporator.

### Risk of injury



**Danger!**

In the event of improper handling or use, there is a risk of injury from rotating fans and sharp edges.

When cleaning below the floor display, the mains plug must be pulled out before cleaning.

Always use suitable protective gloves when cleaning the freshness cooler to avoid injury.

### Risk of short circuit



Water or other liquids that have entered the housing can cause a short circuit. Make sure that no water or other liquids get into the housing of the freshness cooler.



**Risk of damage!**

Improper cleaning and maintenance can damage the freshness cooler or parts of it. Do not use any abrasive, aggressive or easily flammable cleaning agents, brushes with metal or nylon bristles or sharp and metal cleaning objects for cleaning. These can damage the surfaces. Never use glass cleaners or other cleaning agents to clean the coated glass surfaces. These destroy the sensitive coating.

Do not use heaters to manually defrost the freshness cooler.

## Decommissioning, transport and storage **Product details and functionality**

If you plan to take the freshness cooler out of operation for a longer period of time proceed as described below:

- Remove all goods from the freshness cooler.
- Turn off the freshness cooler.
- Wait until the temperature of the freshness cooler has adjusted to the room temperature.
- Clean all parts of the cooler as described in the „Cleaning“ and „Maintenance“ chapters. The air circulation prevents unpleasant odors and mold spores from forming in the refrigerator compartment.
- Make sure that the cooler is level during transport and stands securely on all four feet.
- Secure the cooler against slipping when transporting it in a vehicle.



Improper storage can damage the freshness cooler. Never leave the freshness cooler in a place where it is exposed to direct sunlight. The freshness cooler can be damaged by the high temperatures. Please note that disruptions to the Wurm system will occur if you disconnect a freshness cooler connected via a bus connection from the mains by pulling the mains plug out of the socket.

This chapter provides information on the product details and functionality of the freshness cooler and the individual components that are important for the proper handling of the freshness cooler.

### **Climate class**

Cooling devices must always correspond to one of the climate classes 0 to 8 according to the ISO 23953-2 standard. The climate class specifies specifications for the environment in which the device is operated. The cooler is designed as a device in climate class 3, for which a maximum ambient temperature of 25°C and a maximum relative humidity of 60% are specified. If the actual temperature and humidity values are above the specified values, the energy efficiency of the freshness cooler may decrease. If the actual values significantly exceed the specifications, functional restrictions of the freshness cooler can be expected. Only operate the cooler in an environment that meets the requirements of climate class 3.

### **Cooling unit**

The cooling unit integrated in the freshness cooler begins to work with a delay of around 2 minutes after the freshness cooler is switched on. The freshness cooler does not have a separate on/off switch for the cooling unit, i.e. when you connect the fresh food cooler to the power supply, you put it into operation at the same time. Take all the necessary preparatory measures before you connect the freshness cooler to the power supply (see chapter Commissioning).

### **Housing and cooling storage**

The freshness cooler is structured as follows:

- In the lower part „machine compartment“ is the cooling system and the electrics.
- The four outer panes of glass form the

perimeter of the cold room. Inside the cold room is the goods space for the food to be cooled. This is limited on both sides by the glass panes and the inner baffle pane as well as the glass floor display

- A defrosting channel is located below the floor display in the cold room. The defrost channel is used to drain condensed water.

Condensation occurs during proper operation of the freshness cooler; the moisture contained in the air freezes on the cooling surfaces. For the correspondingly necessary defrosting process, the fresh food cooler has an automatic defrosting function, with the help of which the fresh food cooler defrosts automatically at regular intervals. It is usually not necessary to defrost the cooler manually. To do this, observe the procedure in the chapters on cleaning and maintenance.

## Temperature controller / refrigeration controller

With the help of the temperature controller, the temperature in the goods area is regulated to an adjustable setpoint.



Risk of damage!

The temperature controller is set electronically. All necessary settings for temperature control and automatic defrosting are preset at the factory. Changes to the setting may only be made by authorized specialist personnel. Failure to do so may result in damage to the goods.

The refrigeration controller installed in the freshness cooler is the Modell CRDP-XP



or alternative model



CRA of Wurm GmbH & Co. KG Elektronische Systeme, Morsbachtalstraße 30, D-42857 Remscheid, [www.wurm.de](http://www.wurm.de).



## Troubleshooting and Service



Electric shock and risk of ignition!

If work is carried out improperly on the electrics or on the refrigeration system of the freshness cooler there is a considerable potential for danger.

- Only have work on the electrical system and the refrigeration system carried out by authorized KMW customer service.
- Never allow untrained or unauthorized persons to work on the electrical system or the refrigeration system.

In the event of a fault, check the following points:

- Is the power cord plugged in properly?
- Is there voltage at the socket?
- Is the display active on devices with an electronic temperature controller?

If the temperature in the cooling area is too high, check the following points:

- Were goods accidentally stored that were too warm?
- Did you previously have a longer power outage?
- 

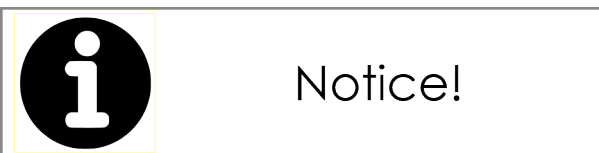

Contact KMW customer service if the fault is not due to any of the causes listed here. When contacting KMW Customer Service, always give the serial number of the cooler and the type of fault or a description of the malfunction. In any case, contact KMW customer service if loud noises and/or strong vibrations occur on the device.

Contact for service queries (e.g. with regard to maintenance and service, repairs, etc.) in principle to your

regionally responsible KMW customer service.

If you do not know the customer service responsible for your region, you can alternatively contact the central KMW customer service at the following contact address:

### Contact address

KMW Kühlmöbelwerk Limburg GmbH  
Limburger Strasse 80  
D- 65555 Limburg  
Telefon 06431 599 0  
Service 0800 59 95 95 9

E-Mail: [kmw@kmw-limburg.com](mailto:kmw@kmw-limburg.com)  
Service: [service@kmw-limburg.com](mailto:service@kmw-limburg.com)  
Internet: [www.kmw-limburg.com](http://www.kmw-limburg.com)

## Technical Data

Year of Manufacturing	since 2022
Temperature class	M1 (-1°C bis +5°C)
Climate class	III (25°C; 60% rF)
Supply voltage	230V; 50Hz
Power consumption	7,40A
Power supply: Usedom 70/900 Usedom 90/1250	6,21 kWh/24h 6,95 kWh/24h
Protection art	IP44
Protection class	1
Refrigerant	R290
Capacity	0,15kg

Dimensions	L/W/H
External dimensions	1080x1100x980mm
Internal dimensions	950x700mm
(Glass display 1)	940x340mm
Display arex	0,99m <sup>2</sup>
Weight	185kg

Dimensions	L/W/H
External dimensions	1395x1100x980mm
Internal dimensions	1270x700mm
(Glass display 1)	1250x340mm
Display area	1,62m <sup>2</sup>
Weight	215kg

## Disposal

### Dispose of packaging



Discard the packaging unmixed. Give cardboard to the waste paper, foils to the recyclables collection.

### Dispose the freshness cooler

(Applicable in the European Union and other European countries with systems for separate collection of recyclables)

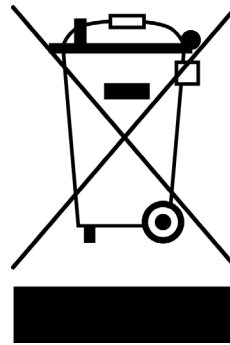

Old devices must not be disposed of in the household waste! Dispose of the freshness cooler according to the disposal laws and regulations applicable in your country (e.g. WEEE) and in accordance with the regulations of the local disposal partner.

Energy label climate class III (25°C;60%r.F.)

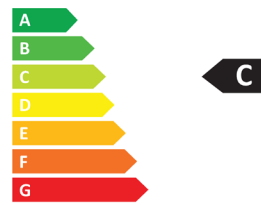

**3614** kWh/annum

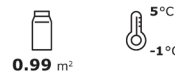

**4088** kWh/annum

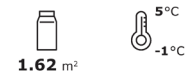

## Declaration of Conformity

# KMW<sup>®</sup>

## KÜHLMÖBELWERK

Qualität aus Deutschland

## EU Declaration of Conformity

Manufacturer: KMW Kühlmöbelwerk Limburg GmbH  
Limburger Strasse 80  
65555 Limburg

Product name: Commercial refrigerated cabinets

Type designation: According to device model designation

The serial number, important technical data and test marks are given on the rating plate of each individual refrigeration appliance.

The manufacturer is solely responsible for issuing this declaration of conformity.

The product described above complies with the provisions of the directives:

- Machinery Directive 2006/42/EC of May 17, 2006
- EMC Directive 2014/30/EC of February 26, 2014

The compliance of the product described above with the essential requirements of the directive is demonstrated by the technical documentation and full compliance with the following standards:

Applied harmonized standards for Machinery Directive 2006/42/EG

DIN EN 60335-1:2020-08; VDE 0700-1:2020-08

DIN EN 60335-289:2018-10; VDE 0700-89:2018-10

DIN EN 62233:2008-11; VDE 0700-366:2008-11

DIN EN 62233 Correction 1:2009-04; VDE 0700-366 correction 1:2009-04

DIN EN ISO 12100:2011-03

Applied harmonized standards for EMC directive 2014/30/EU:

DIN EN IEC 61000-3-2:2019-12; VDE 0838-2:2019-12

DIN EN 61000-3-3:2020-07; VDE 0838-3:2020-07

DIN EN 55014-1:2018-08; VDE 0875-14-1

DIN EN 55014-2:2016-01; VDE 0875-13:2016-01

Other standards applied in the design and construction of the products:

DIN EN 378-1:2021-06

DIN EN 378-2:2018-04

DIN EN ISO 23953-1:2016-03

DIN EN ISO 23953-2:2016-03

DIN EN IEC 60079-0:2019-09 for R-290 devices, R-600a devices

In case of a technical change to the product described above that has not been agreed with us, this declaration loses its validity.

KMW Kühlmöbelwerk Limburg GmbH

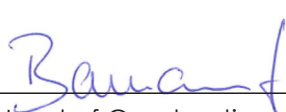
  
Head of Construction

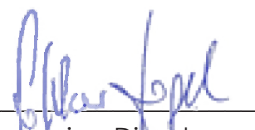
  
Managing Director

## Imprint

# KMW Kühlmöbelwerk Limburg GmbH

Gewerbegebiet Offheim  
Limburger Straße 80  
D-65555 Limburg

Tel.: +49 (0) 64 31 / 5 99 - 0  
Fax: +49 (0) 64 31 / 5 39 67  
Service: +49 (0)800 / 599 59 59  
(kostenfrei aus dem dt. Festnetz)

[kmw@kmw-limburg.com](mailto:kmw@kmw-limburg.com)  
[www.kmw-limburg.com](http://www.kmw-limburg.com)

### ©Copyright

Reprint or duplication (also in extracts) only with the permission of:  
KMW Kühlmöbelwerk Limburg GmbH Limburger Strasse 80  
D-65555 Limburg

This publication, including all of its parts, is protected by copyright.

Any use outside the narrow limits of copyright without the consent of KMW Kühlmöbelwerk Limburg GmbH is inadmissible and punishable.

This applies in particular to reproductions, translations, microfilms and the Feeding and processing in electronic systems.

Manufactured in 2022 by:

KMW Kühlmöbelwerk Limburg GmbH Limburger Strasse 80  
D-65555 Limburg

Article number: 3042585